



BASEMENT FINISH

Prior to beginning work for the finish of a lower level or basement, a building permit application must be completed and submitted to the Inspection Department along with two sets of construction drawings and a proposed floor plan. The construction drawings must show what is existing such as window openings, framed walls, exterior wall insulation, etc. The proposed floor plan must indicate the use of the rooms (ie. Bedroom, rec room, bathroom), the location of new walls to be constructed, door/window openings, etc. The permit application should indicate the amount of work to be done, what work if any was done when the house was built and to what extent. Any heating/mechanical work, plumbing work and/or electrical work will require separate permits. Please allow a minimum of five to ten working days for the plan review process. You will be contacted by the Inspection Department when the permit is ready for issue.

SMOKE DETECTORS

A smoke detector is required at a point centrally located in the hallway or area giving access to each separate sleeping area, on each level of the house and in every sleeping room throughout the entire house. In areas and rooms being finished, the smoke detectors shall receive their primary power from the building wiring and be equipped with battery backup. Existing finished areas may be solely battery operated. CO Alarms are required in each dwelling located within ten feet of each sleeping room.

MINIMUM CLEAR DIMENSIONS

- 3'-0" Hall Width
- 7'-0" Ceiling height in habitable rooms (living, sleeping, eating, or cooking)
- 7'-0" Ceiling height in rooms other than habitable rooms (halls, bathrooms, and closets)
- 2'-6" Width for toilet (centered) with 24" clearance in front
- 3'-0" Stairway width

MINIMUM ROOM SIZE

Habitable rooms shall have a floor area of not less than 70 square feet and shall not be less than 7 feet in any horizontal dimension.

EGRESS (ESCAPE WINDOWS) AND WINDOW WELLS

All basements and each bedroom must have one egress window or door. See Egress Escape Windows and Window Wells handout for details.

NATURAL LIGHT AND VENTILATION

Habitable rooms (rooms used for living, sleeping, eating or cooking) must be provided with natural light by means of exterior glazed openings (windows) with an area not less than one-eighth (8%) of the floor area of which half of such glazed openings shall be open able to natural ventilation. 4% ventilation will be required for the area. This can be accomplished by windows or a bath fan that is turned on when the lights are turned on.

FRAMING

Lumber must be grade-stamped. The bottom wall plate must be treated wood and securely fastened to the floor slab with nails/screws or construction adhesive. **Prior to framing inspection, rough-in inspections must be completed on any plumbing, heating, and electrical alterations or additions.** See Cutting and Notching section in this handout for details. Engineered floor trusses/beams must not be cut, notched, or altered without written approval from the manufacturer.

STAIRWAYS

Minimum stairway headroom clearance is 6'-8" (measured vertically from any plane parallel and tangent to the stairway tread nosing to the above at all points.)

Landings at the bottom of the stairways require 36" of depth before the door or wall.

ENCLOSED AREA UNDER STAIRS

The walls and ceiling of an enclosed space below an interior stairway shall be protected with one layer of 1/2" type X gypsum board. If the area is greater than 100 square feet, a heat run shall be provided to the area for ventilation.

INSULATION

Foundation walls require R-10 insulation. Rigid foam insulation with a flame spread greater than 75 and/or a smoke density rating greater than 450 must be protected with 1/2" gypsum board or 1/4" plywood.

Bathtub openings and other penetrations in the floor above must be filled with fiberglass or foam insulation (see plumbing section for more information on trap accesses.)

A vapor barrier (4 mil poly or equal) is required on the warm side of the insulated exterior walls. This includes behind showers and tubs on exterior walls. Water resistive gypsum board cannot be applied over another vapor barrier (such as 4 mil poly) or on ceilings.

DRAFT STOPPING

Draft stopping will be inspected with insulation. See attached handout for details.

CERAMIC TILE

Ceramic tile in the shower/tub area must be applied over a water resistant gypsum backing board. For a shower, concrete board is recommended.

SAFETY GLAZING

Safety glazing is required in doors and enclosures for hot tubs, whirlpools, saunas, steam rooms, bathrooms and showers. Safety glazing must be used in any portion of a building wall enclosing these compartments where the bottom exposed edge of the glazing is less than 60" above the walking surface.

Safety glazing is required in fixed or operable panels adjacent to a door where the nearest exposed edge of the glazing is within a 24" arc of either vertical edge of the door in a closed position and where the bottom exposed edge of the glazing is less than 60" above the walking surface.

WALL BOARD

Gypsum board (sheetrock) shall be installed as per attached requirements.

Gypsum Manual Sections are as follows:

5. Application of Gypsum Board

Note: For wood framing, refer to Section 1.3. Installation of steel framing should be in accordance with ASTM Standard C 754.

5.2 Application of Single Ply Gypsum Board to framing members.

5.2.1 Maximum spacing of framing members for single ply gypsum board construction should not exceed those shown in Table 1.

Table 1 Maximum Framing Spacing		
Single Ply Gypsum Board (Thickness)	Application to Framing	Maximum O.C. Spacing of Framing
Inches	Direction	Inches
Ceilings: +3/8 1/2 1/2 5/8	*Perpendicular	16
	Perpendicular	16
	*Parallel	16
	Parallel	16
5/8"	*Perpendicular	24
	Perpendicular	24
Sidewalls: 3/8 1/2 5/8	Perpendicular or Parallel	16
	Perpendicular or Parallel	24
	Perpendicular or Parallel	24

*On ceilings to receive a water base texture material, either hand or spray applied, install gypsum board perpendicular to framing and increase board thickness from 3/8" to 1/2" for 16" o.c. framing and from 1/2" to 5/8" for 24" o.c. framing.
+Should not support thermal insulation.

5.2.2 In single ply installation, all ends and edges of gypsum board should occur over framing members or other solid backing except where treated joints occur at right angles to framing or furring members.

5.2.3 Stagger end joints of each course and layer on the same side of framing members and with joints in the base layer of the opposite side of framing members.

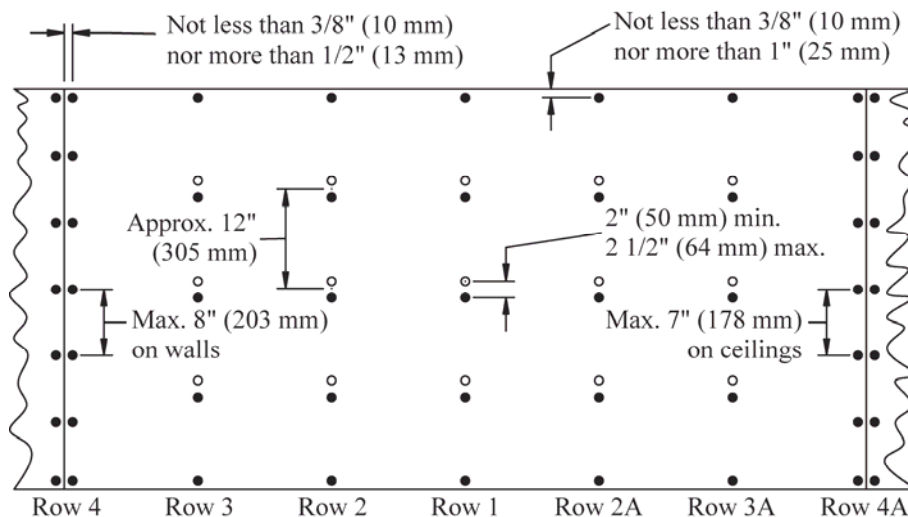

Figure 3 – Double Nailing

5.2.4 Edge joints PARALLEL to framing member should be staggered on each side of the assembly.

5.3 Nailing for Single Ply Application Over Wood Members.

Single ply application is shown in Table 2

Table 2	
Nailing Schedule for Single Ply Gypsum Board	
Gypsum Board Thickness	Minimum Nail Length
<u>Inches</u>	<u>Inches</u>
1/4	(2)
3/8	1-1/4
1/2	1-3/8
5/8	1-1/2

5.3.3 When screws are used in lieu of nails, they should penetrate framing not less than 5/8" and be spaced a maximum of 12" o.c. for ceilings and 16" o.c. for walls where the framing members are 16" o.c. Screws should be spaced a maximum of 12" o.c. for ceilings and walls where framing members are 24" o.c.

5.3.4 A combination of fasteners consisting of nails along the perimeter and screws in the field of the gypsum board may be used.

5.3.1 Nails for single nailing should be spaced a maximum of 7" o.c. on ceilings, and a maximum of 8" o.c. on walls. (See Figure 2.)

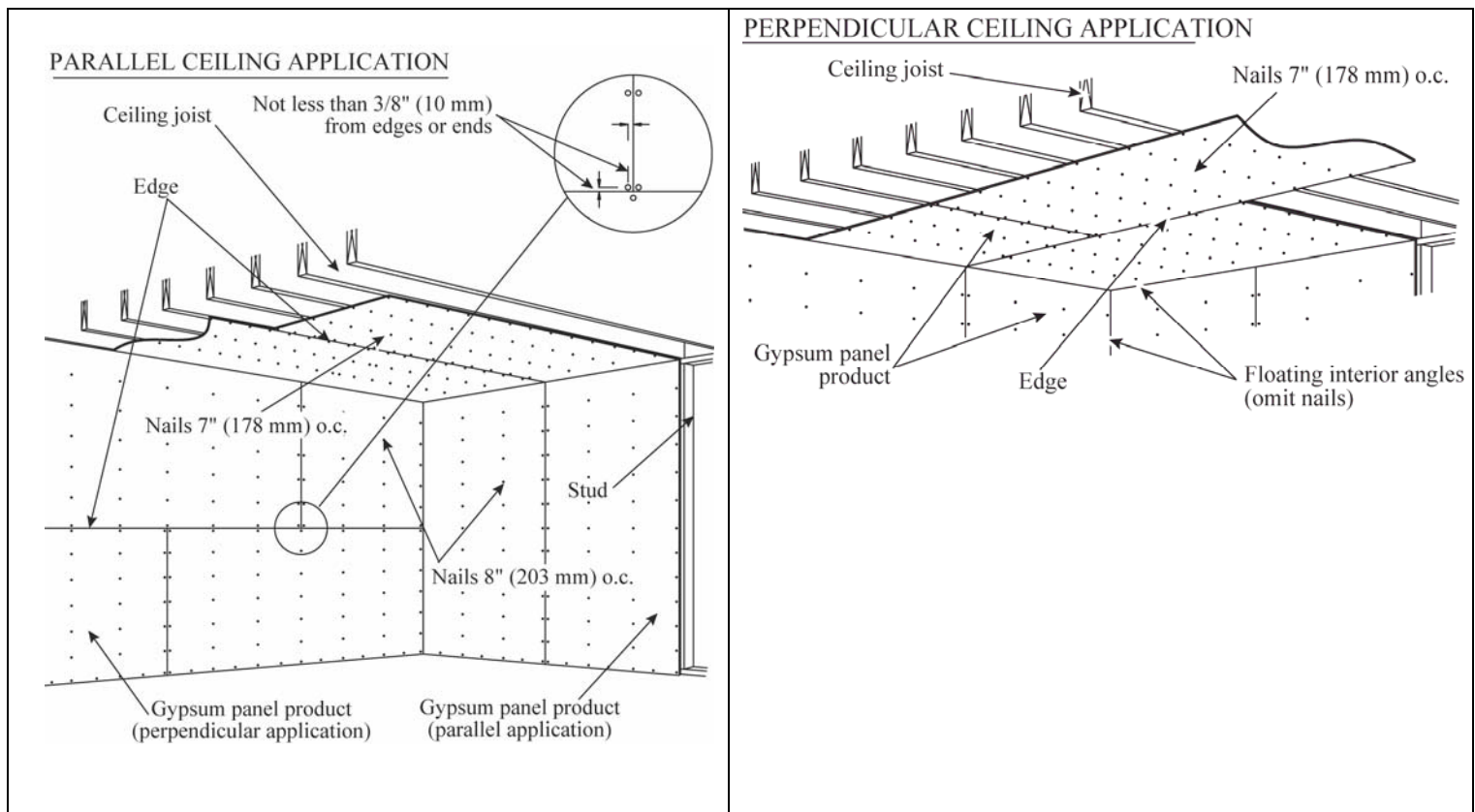

Figure 2 – Single Nailing

15. Application of Gypsum Board to Receive Adhesively Applied Ceramic or Plastic Wall Tile or Plastic Finished Wall Panels

15.1 Framing around tub enclosures and shower stalls should allow sufficient room so that inside lip of tub, prefabricated receptor or hot-mopped sub-pan will be properly aligned with face of gypsum board. (See Figures 3 and 4) This may necessitate furring out from studs the thickness of gypsum board to be used 1/2" or 5/8" less thickness of the lip, on each wall abutting a tub, receptor, or sub-pan. Interior angles should be framed or blocked to provide solid backing for interior corners.

15.2 When framing is spaced more than 16" o.c, suitable blocking or backing should be located approximately 1" above top of tub or receptor and at gypsum board horizontal joints in area to receive tile. When surface finish is ceramic tile, spacing of studs 2-1/2" thick or less should not exceed 16" o.c. Studs 3-1/2" or more in thickness may be spaced 24" o.c. provided blocking described above is utilized.

Note to Specifier: Appropriate blocking, headers or supports should be provided to support tub, other plumbing fixtures and to receive soap dishes, grab bars, towel racks and similar items as may be required.

15.3 Water resistant gypsum backing board (ASTM C 630) should be used as a base for application of ceramic or plastic wall tile or plastic finished wall panels in wet areas such as tub and shower enclosures. Regular gypsum board may be used as a base for tile and wall panels in dry areas. Gypsum board should not be used in extremely critical exposure areas such as saunas, steam rooms or gang shower rooms. Gypsum board used as a base for tile or wall panels in tub or shower enclosures, etc., should not be foil backed and should not be applied over any vapor retarder. *Water resistant gypsum backing board should not be used on ceilings or soffits.*

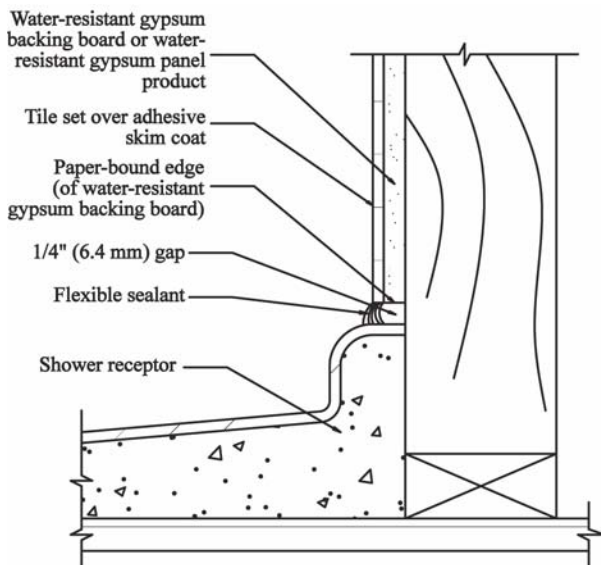
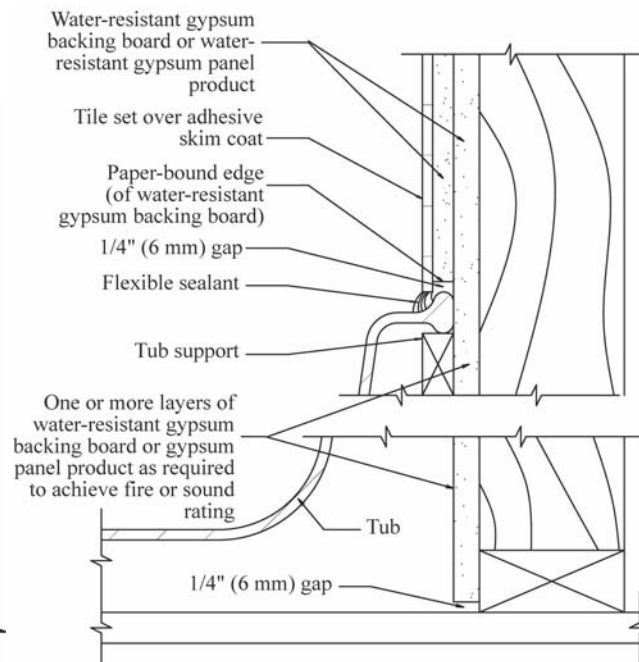
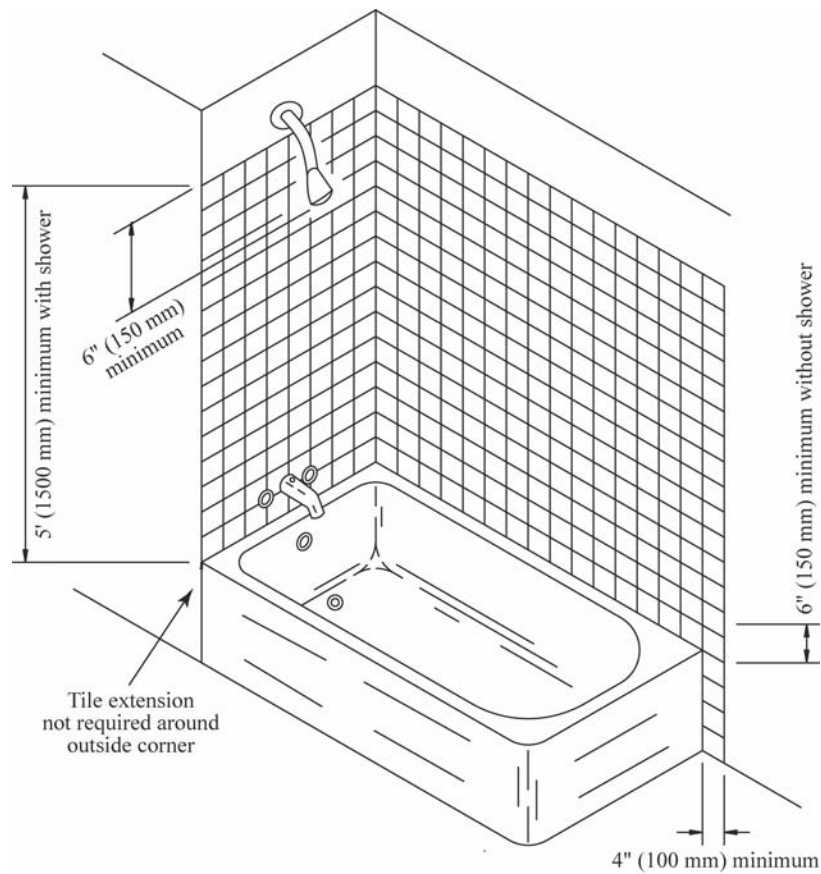

Figure 3



Figure



Note: A single layer of asphalt impregnated felt, 15 lb. or less, applied as part of the wall system, is not considered a vapor retarder.

15.4 Water resistant gypsum backing board should be applied perpendicularly with factory edge spaced a minimum of $\frac{1}{4}$ " above lip of receptor, tub or sub-pan. Shower pans, receptors or tubs should be installed prior to erection of gypsum board. **FOR FIRE OR SOUND RATED ASSEMBLIES, THE BASE PLY GYPSUM BOARD SHOULD EXTEND FULL HEIGHT, FLOOR TO CEILING.**

FIRE BLOCKS AT SOFFITS

Section 708.2.1. At all interconnections between concealed vertical and horizontal spaces such as occur at soffits, drop ceilings and cove ceilings.

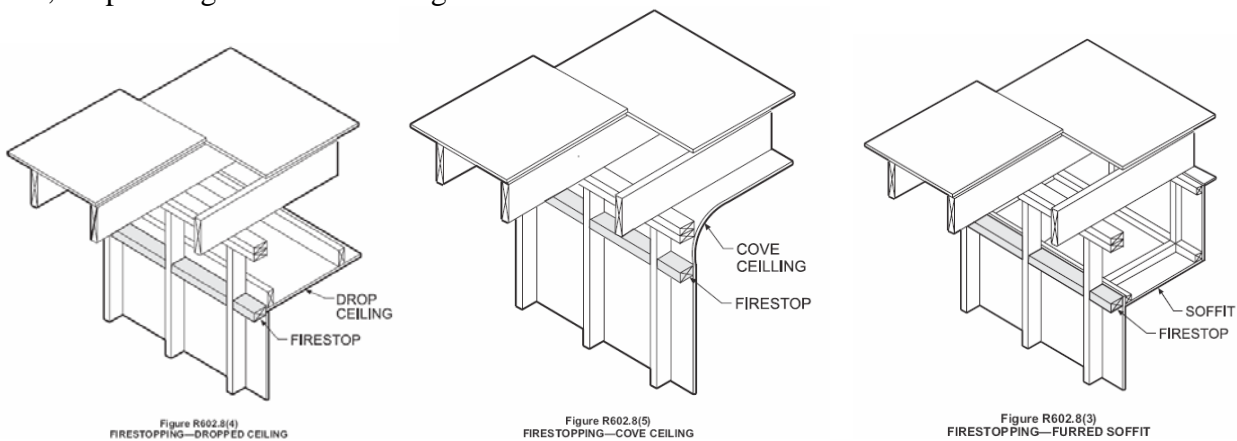

FIRE BLOCKS IN CONCEALED SPACES AT STAIRS

IRC Section 708.2.1. In concealed spaces between stair stringers at the top and bottom of the run and between studs along and in line with the run of stairs if the walls under the stairs are unfinished.

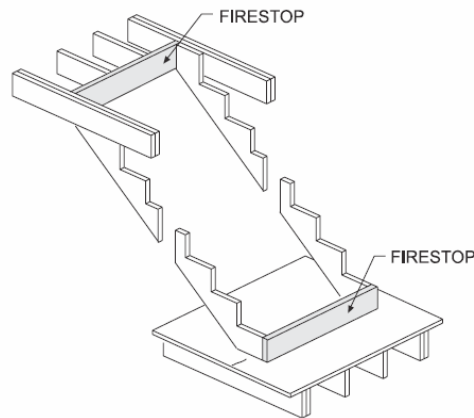

Figure R602.8(7)
FIRESTOPPING—AT STAIRWAYS

FIRE BLOCKS AT OPENINGS

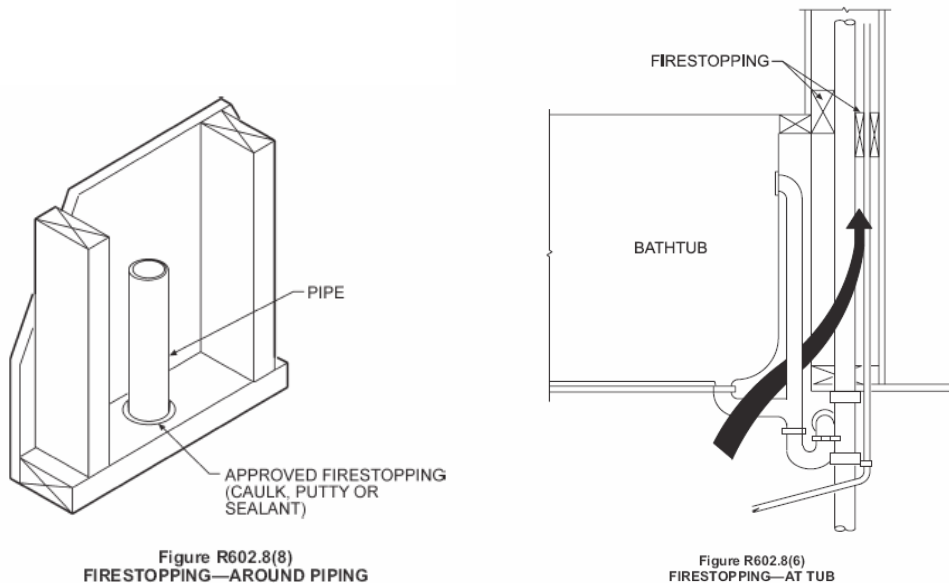

Figure R602.8(8)
FIRESTOPPING—AROUND PIPING

Figure R602.8(6)
FIRESTOPPING—AT TUB

CUTTING AND NOTCHING

IRC Section 602 Cutting and Notching. In exterior walls and bearing partitions, any wood stud may be cut or notched to a depth not exceeding 25% of its width. Cutting or notching of studs to a depth not greater than 40% of the width of the stud is permitted in nonbearing partitions supporting no loads other than the weight of the partition.

IRC Section 602. Bored Holds. Bored holes not greater than 60% of the width of the stud is permitted in nonbearing partitions or in any wall where each bored stud is doubled, provided not more than two such successive doubled studs are so bored.

In no case shall the edge of the bored hold be nearer than 5/8 inch to the edge of the stud. Bored holes shall not be located at the same section of stud as a cut or notch.

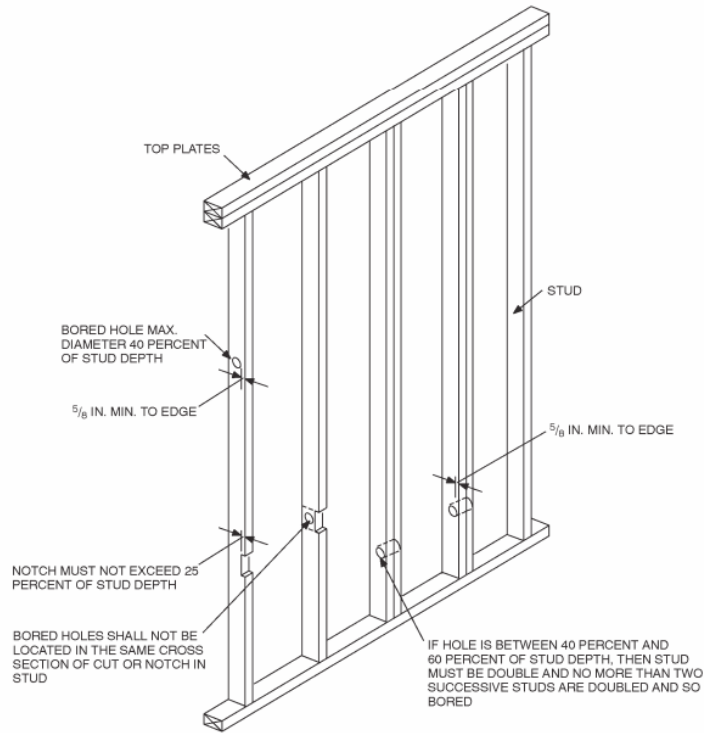

For SI: 1 inch = 25.4 mm.

Note: Condition for exterior and bearing walls.

FIGURE R602.6(1)
NOTCHING AND BORED HOLE LIMITATIONS FOR EXTERIOR WALLS AND BEARING WALLS

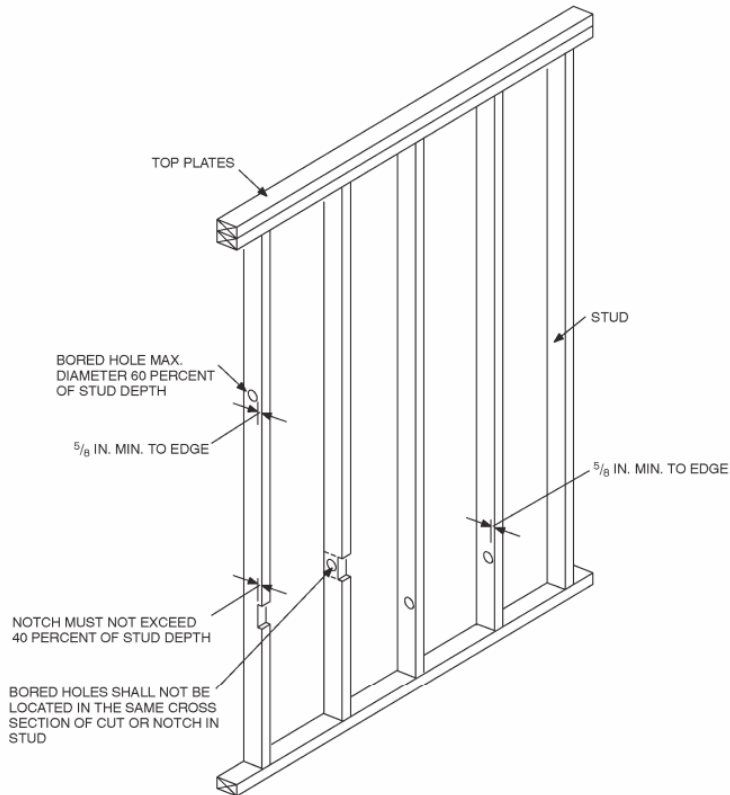

or SI: 1 inch = 25.4 mm.

FIGURE R602.6(2)
NOTCHING AND BORED HOLE LIMITATIONS FOR INTERIOR NONBEARING WALLS